



Instrução de Montagem

LOJA **Rudnick**

www.lojarudnick.com.br

Acessórios

A	18201487		4,5 x 50	02
B	18200275		4,5 x 25	04
C	18201134		4,0 x 14	40
D	18200294		3,5 x 12	04
E	10500005		Ø8,0 x 30	08
F	18300331		Rapid	04
G	18400061		Tambor	04
H	18301575		Cantoneira	07
I	18302608		Sapata	02
J	18509798		Dobradiça Alta	02
K	18301108 18306308		Cor Branco Cor Ravena Tapa Furo 19mm	04

Escivaninha Lysa

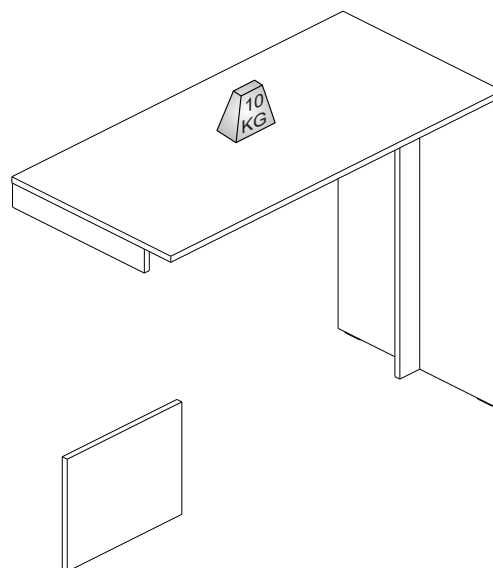
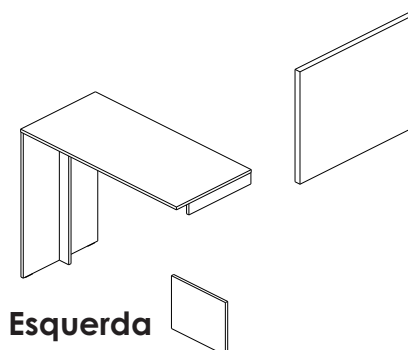
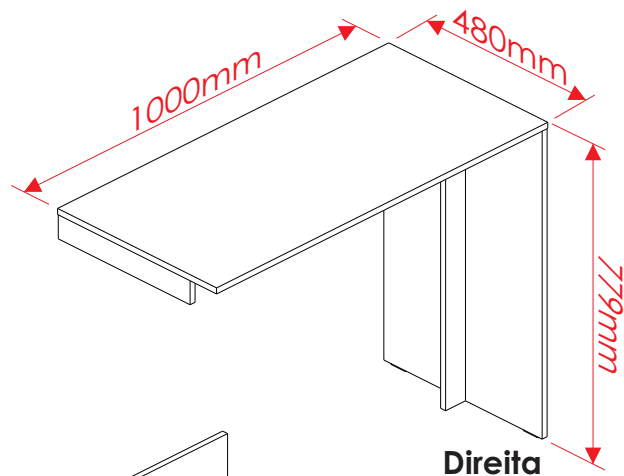

Utilizar a régua abaixo para medir os acessórios.



Atenção!

Pesos máximos recomendados com cargas uniformemente distribuídas.



Atenção!

Para acessar o vídeo de montagem, você deve abrir a câmera do seu celular e apontá-la para o código QR ao lado.



Componentes

N.	Componentes	Código	Quant.
01	Tampo	T18444	01
02	Lateral Menor	L09149	01
03	Lateral Maior	L09150	01
04	Travessa Lateral	X17720	01
05	Travessa Superior	X17721	01
06	Porta	P23684	01



Atenção!

Forrar o chão com o papelão das embalagens para efetuar a montagem

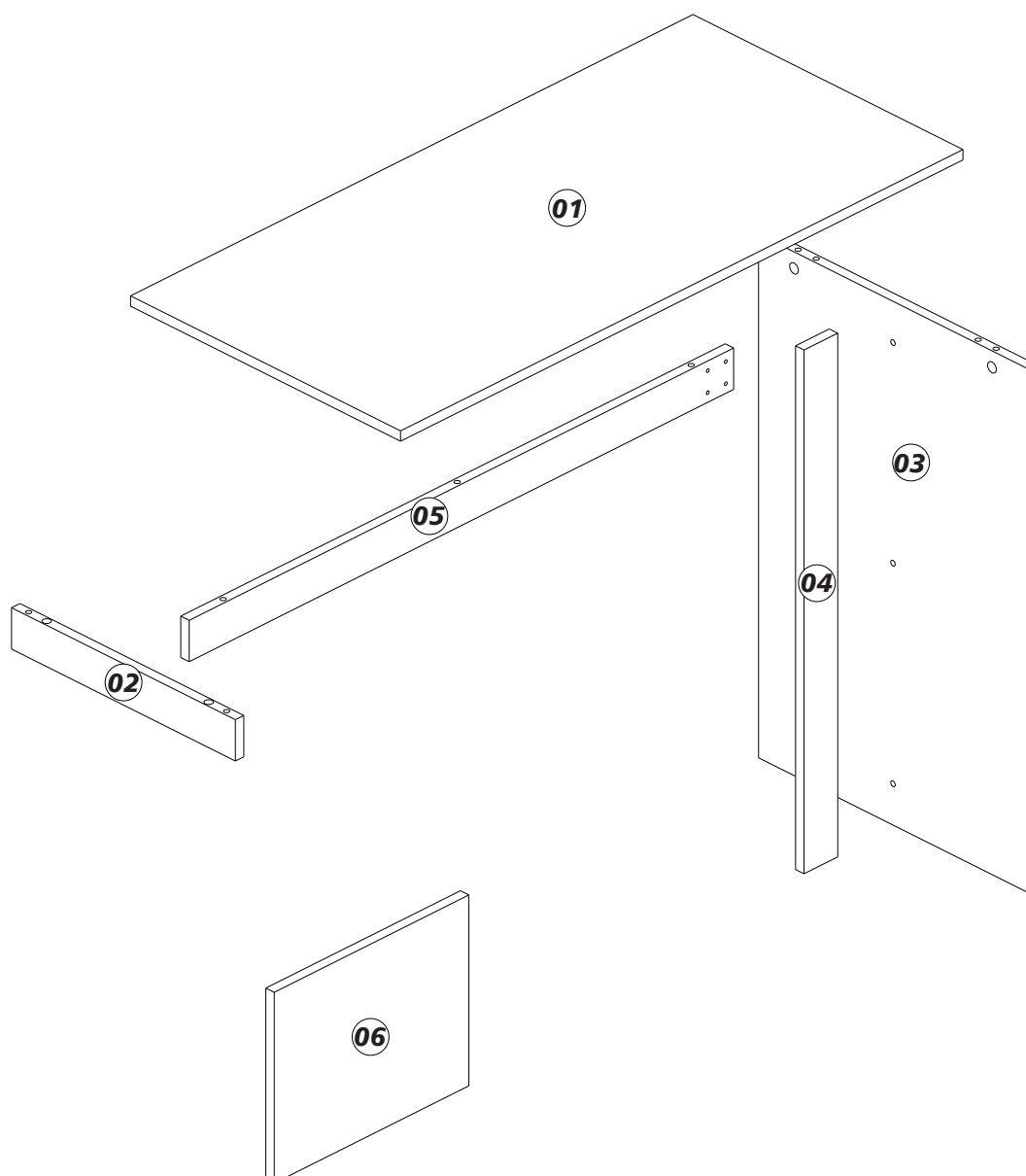
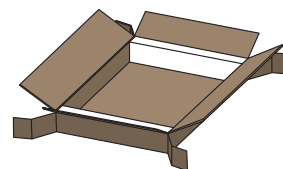

Componentes - Peças

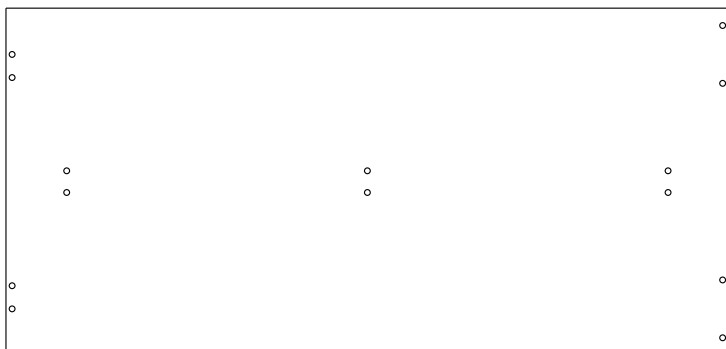

01 - 1000x480x15mm - 1x

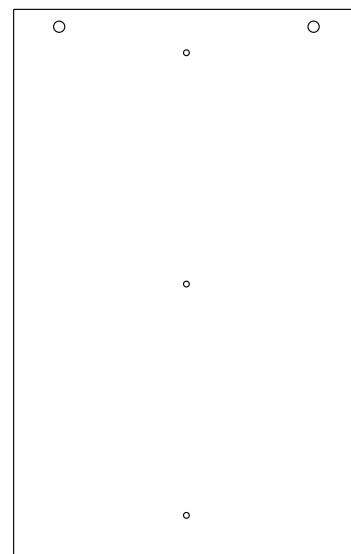

03 - 760x478x15mm - 1x

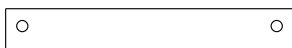

02 - 398x60x15mm - 1x

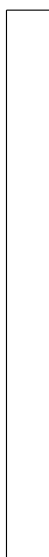

04 - 760x60x15mm - 1x



06 - 346x277x15mm - 1x

Opções

Esquerdo

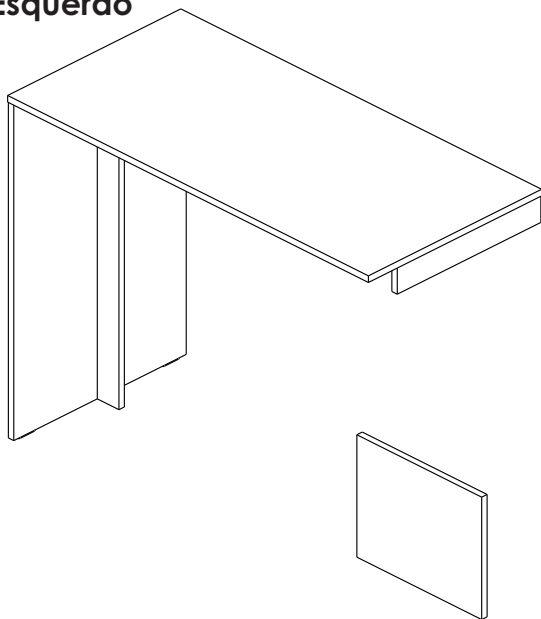

Direito

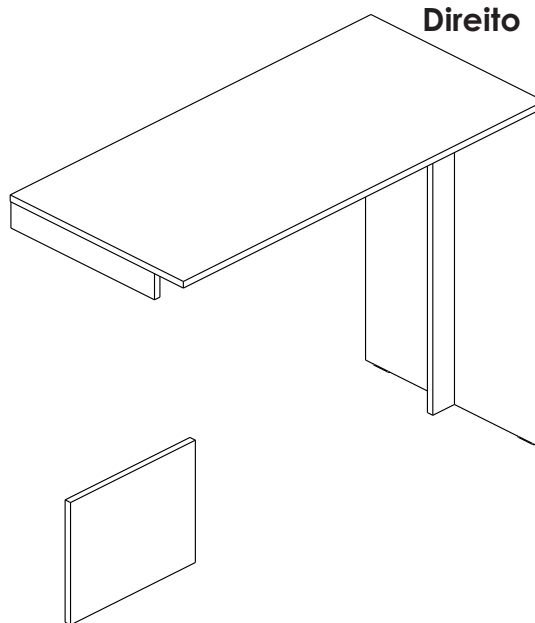

Após montar sua Mesa Cabeceira (vendida separadamente) siga os seguintes passos:

Passo 01- Esquerda

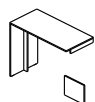

Obs.: Antes de fixar a lateral menor, verifique a medida X e lado que o cliente quer a escrivaninha.

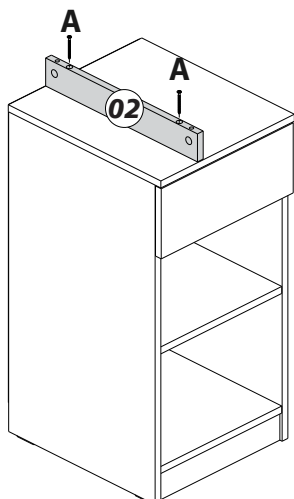
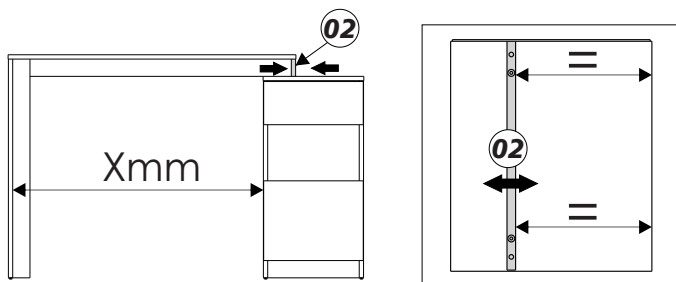

Passo 01- Direita

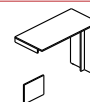

Obs.: Antes de fixar a lateral menor, verifique a medida X e lado que o cliente quer a escrivaninha.

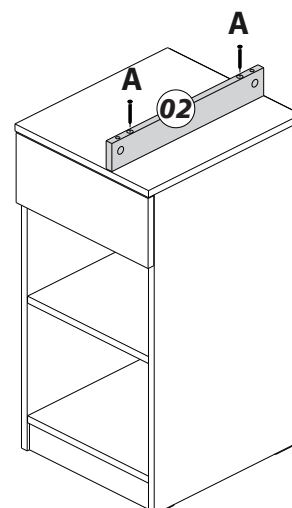
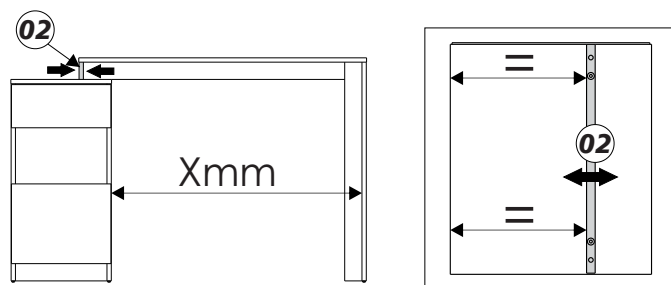

Passo 02

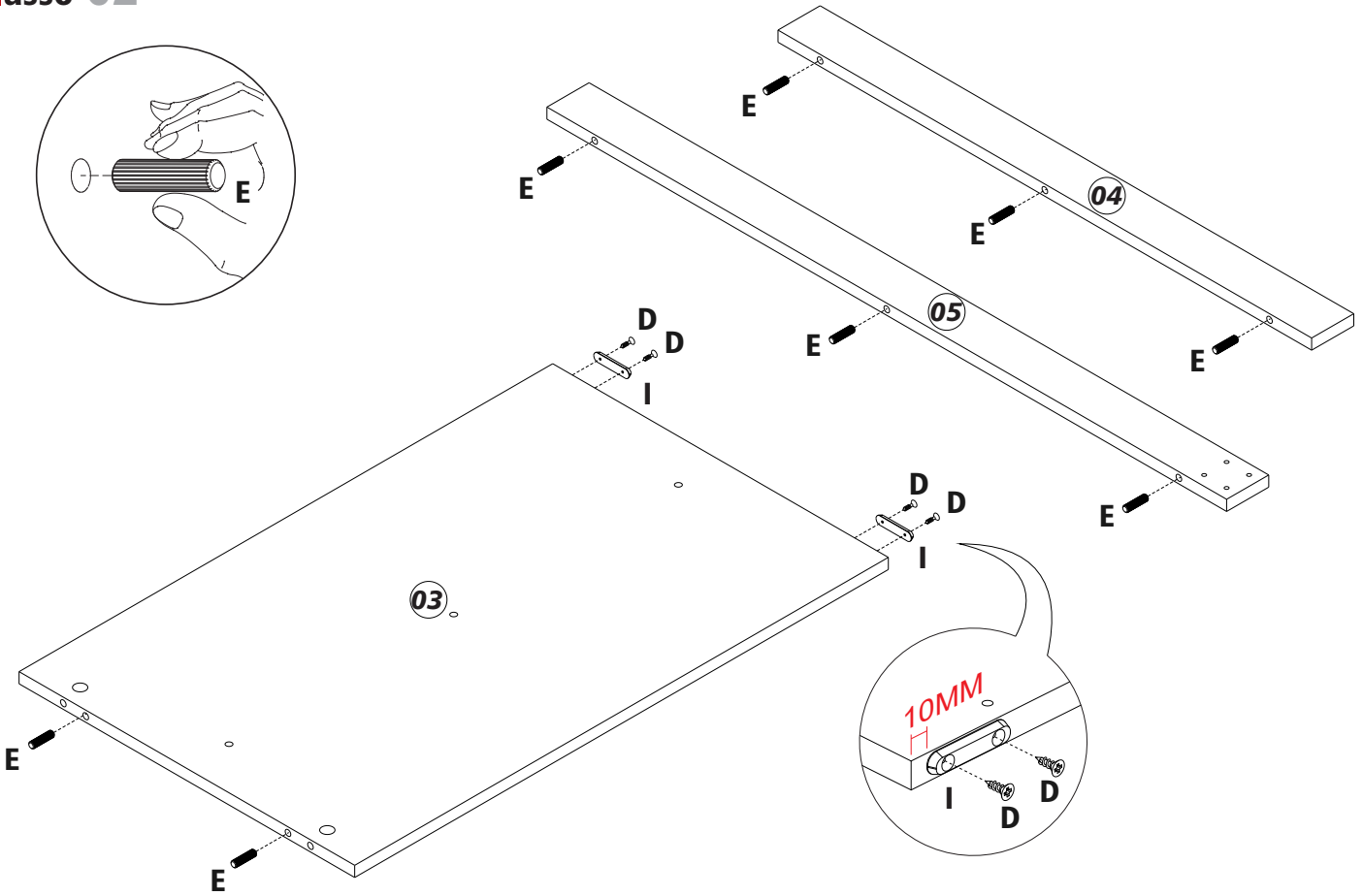

Passo 03- Esquerda

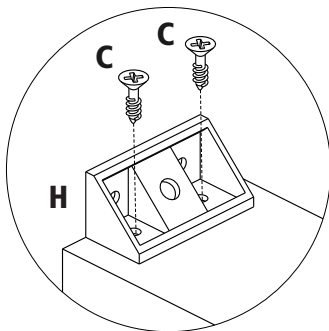
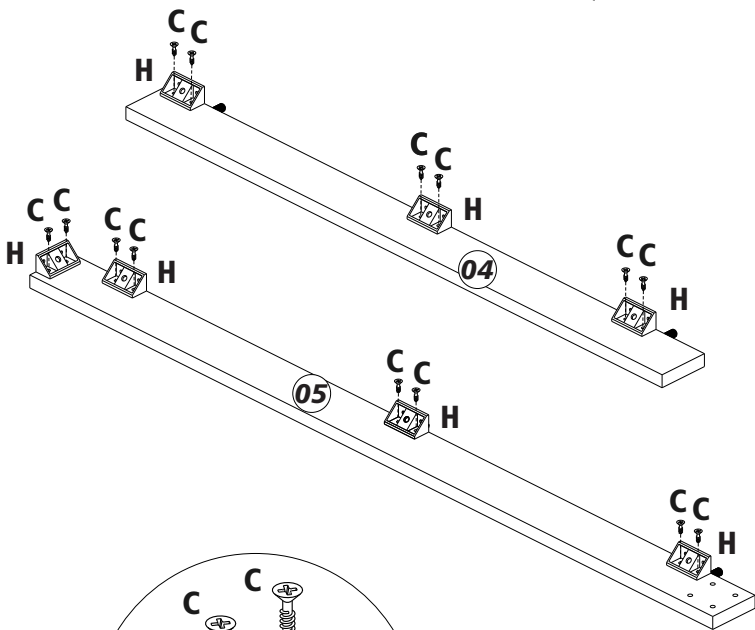
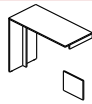

Passo 03- Direita

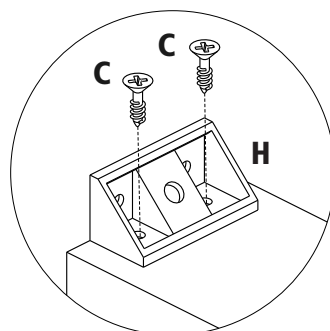
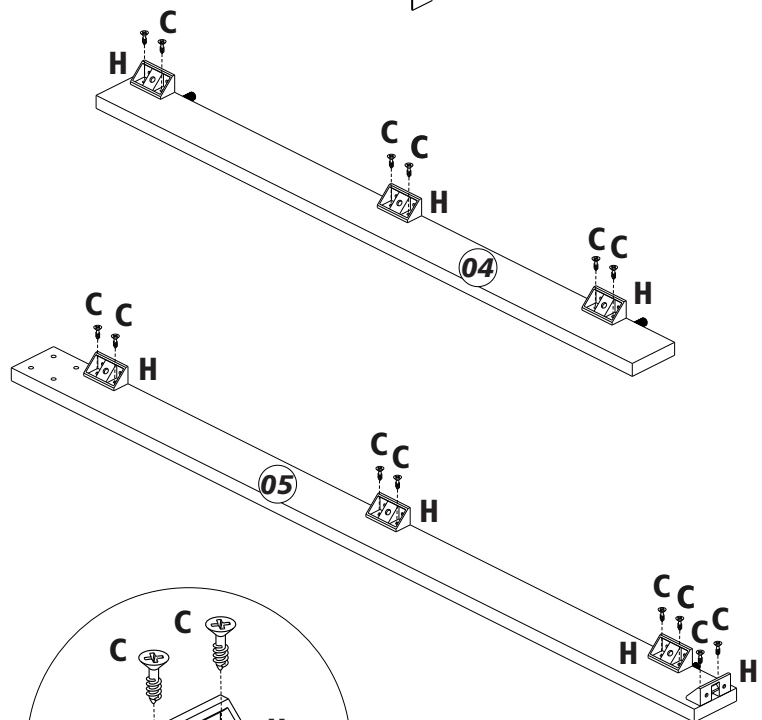
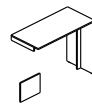

Passo 04 Esquerda

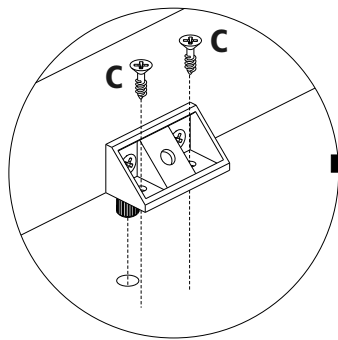
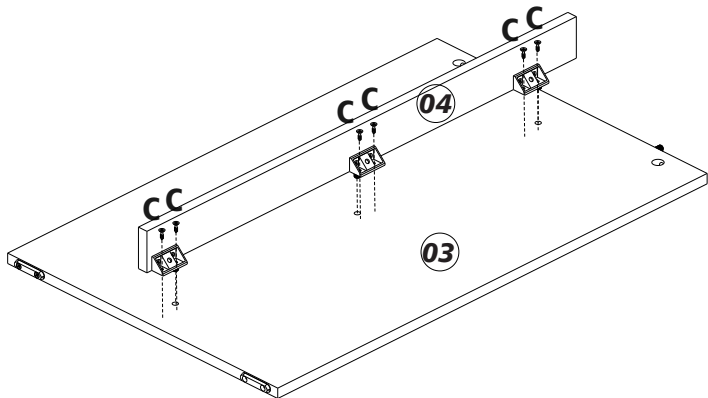
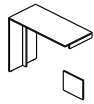

Passo 04 Direita

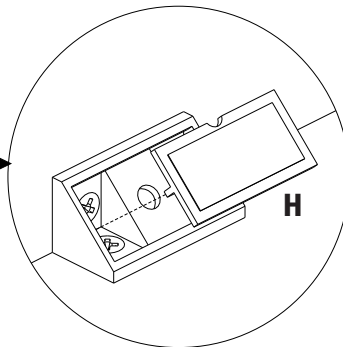
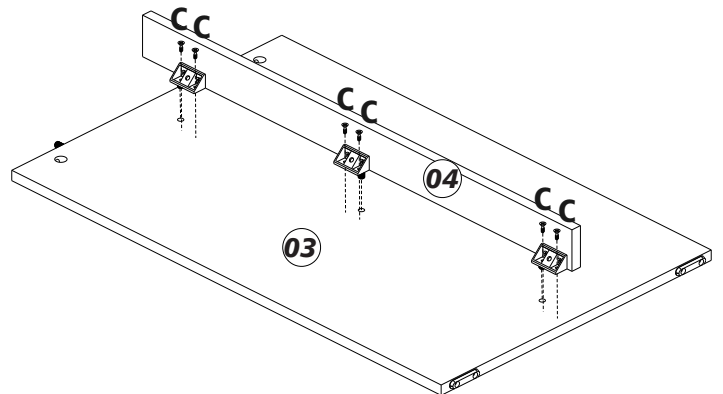
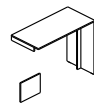

Passo 05 Esquerda

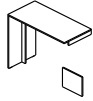

Atenção para a posição dos rapids (F).

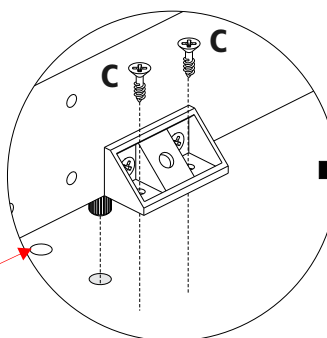
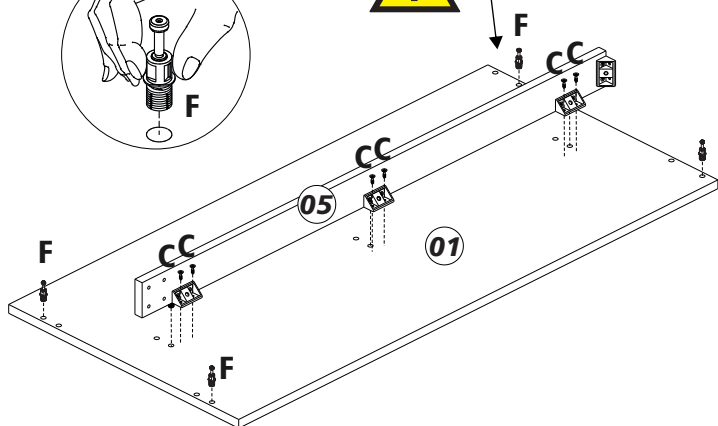
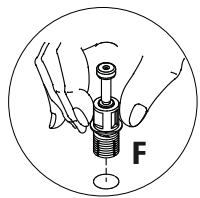

Passo 05 Direita

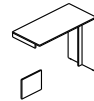

Atenção para a posição dos rapids (F).

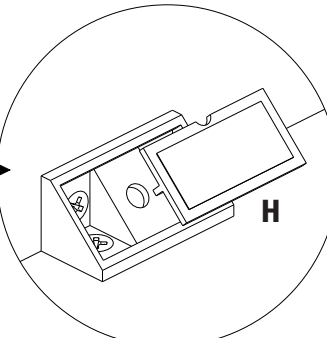
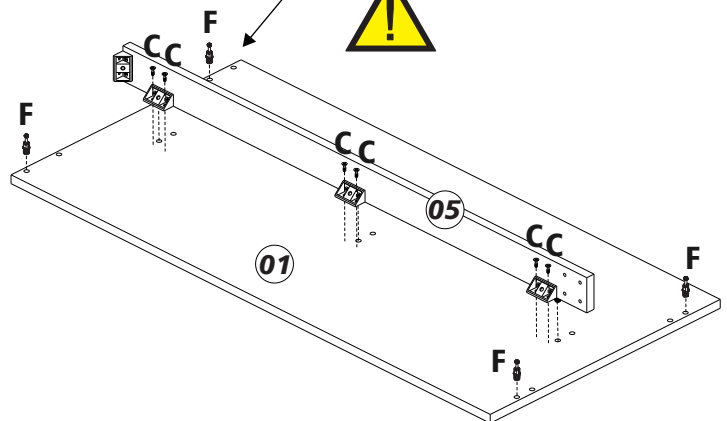

Passo 06 Esquerda

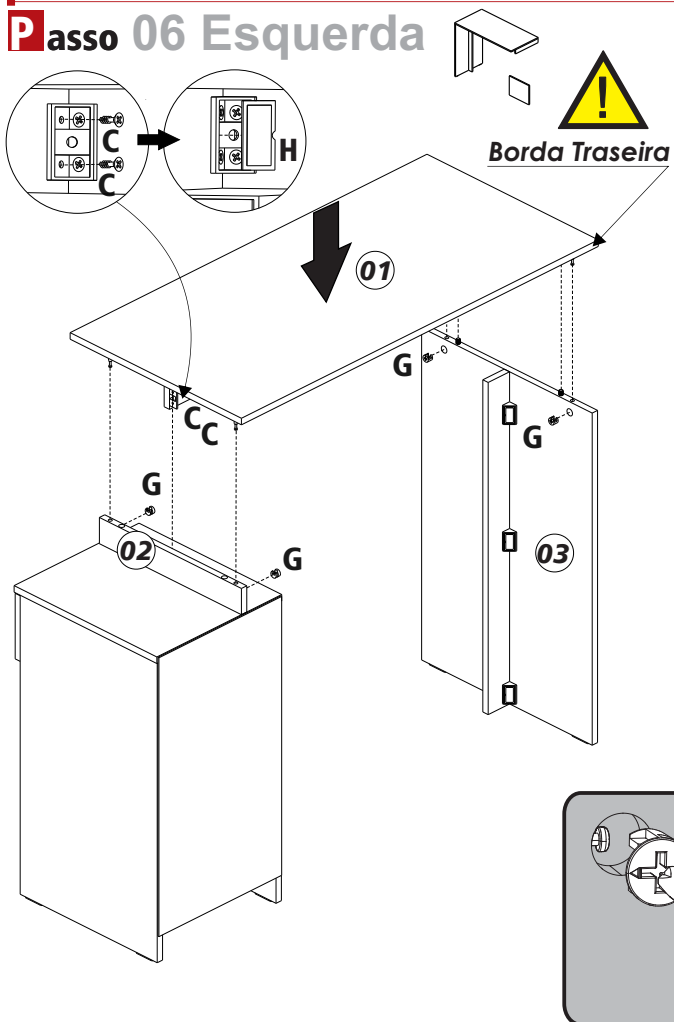

Passo 06 Direita

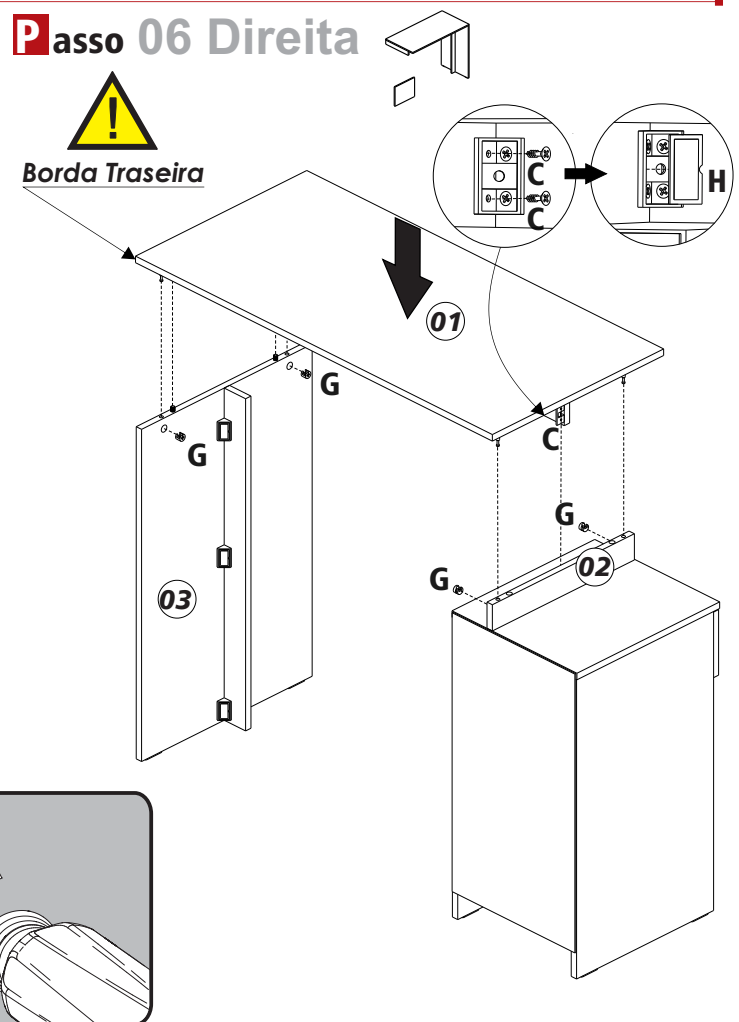

Passo 07 Antes de fixar os parafusos 'B', garanta que as peças estão no esquadro, mesma fixação para os dois lados.

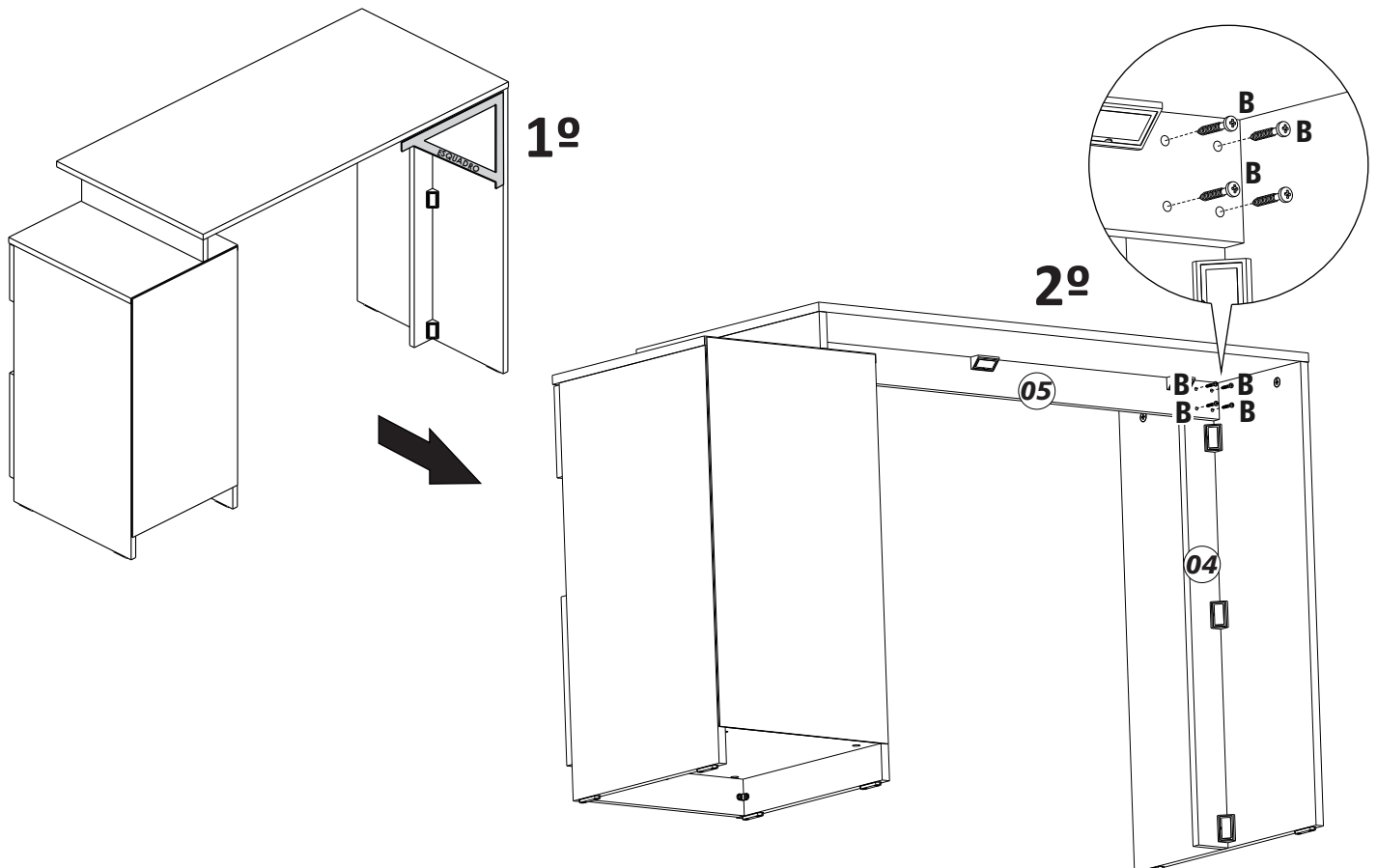

Passo 08

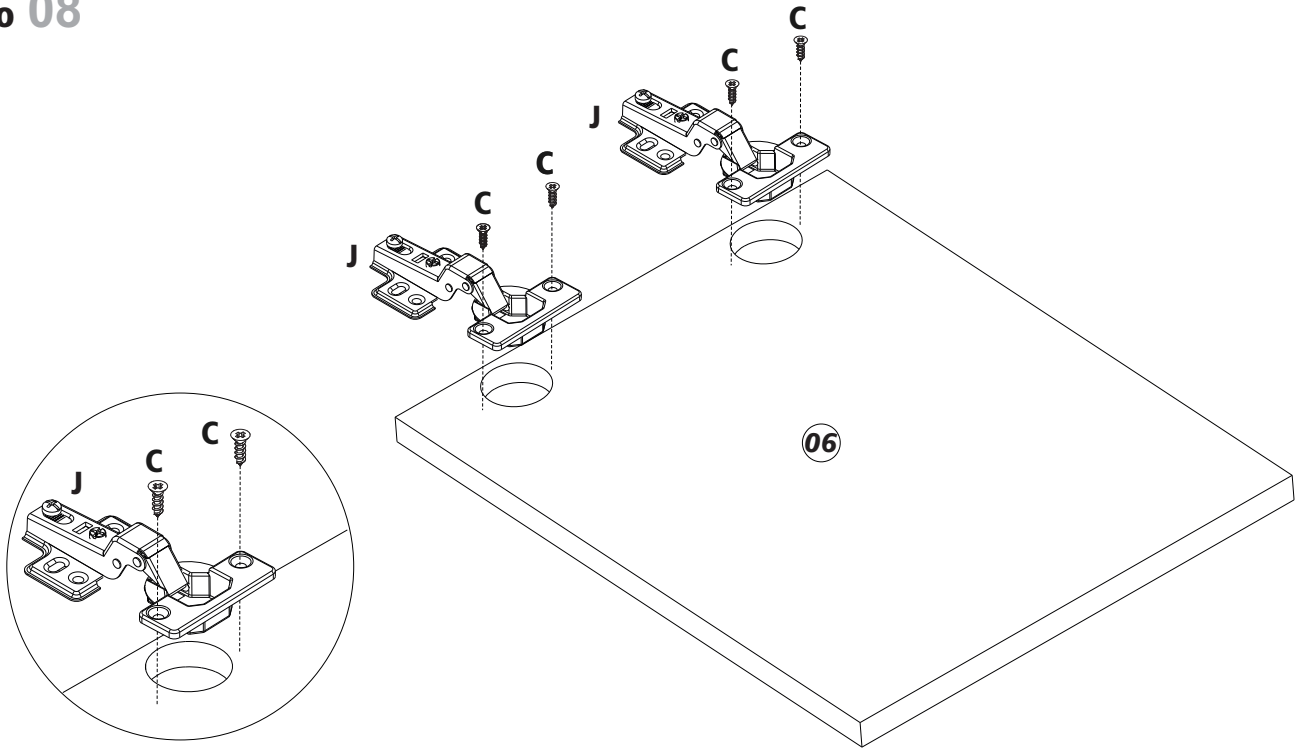

Passo 09

Deixar a porta 6mm acima da prateleira

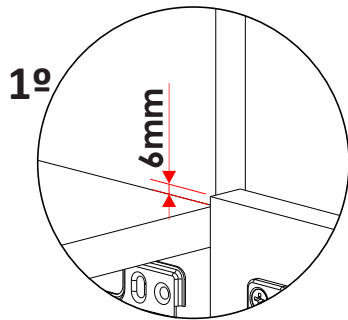

Após alinhe a porta e faça uma marcação e em seguida parafuse:

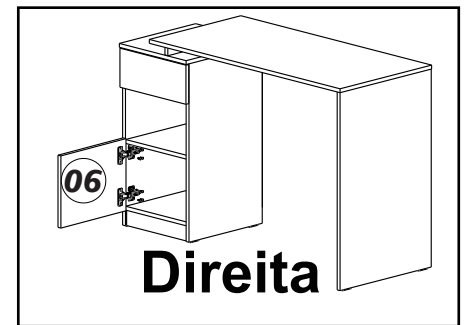
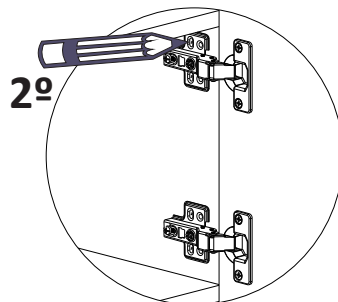

Se necessário fazer a regulagem:

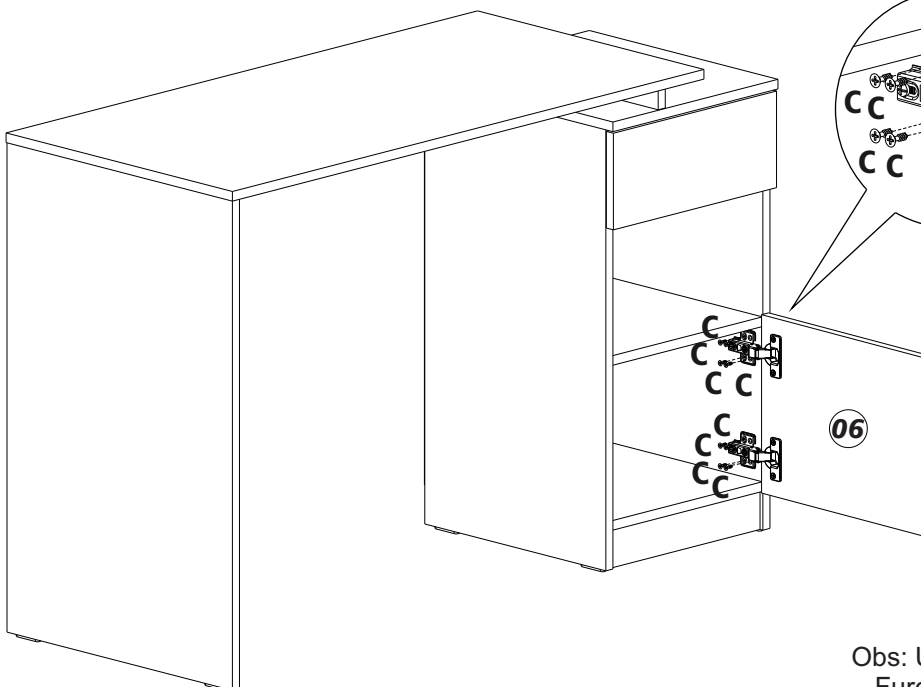
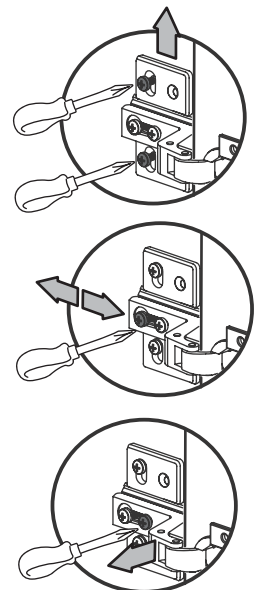

Atenção!

Obs: Utilizar todos os Tapa Furos, para melhorar o acabamento e utilização do produto.

